

BANCHI TRAFILA A MANO

MANUAL DRAWBENCHES · BANCS D'ETIRAGE MANUEL · BANCOS TREFILADORA DE MANO



Banchi trafilatura con solida struttura in ferro saldato, dotati di robusta catena. Gli ingranaggi ruotano su boccole autolubrificanti e la catena, a differenza di altri banchi, è supportata da strisce di materiale antiusura. Hanno due velocità di trafilatura: la prima in presa diretta e la seconda con rapporto di riduzione di 4:1 per i fili più grossi. Sono disponibili nella versione standard (utilizza la pinza BT180T) o corta, fornito con apposita pinza.

Drawbenches with stout structure in welded iron, provided with a strong chain. The gears rotate on self-lubricating bushes; the chain also, unlike other benches, is supported by strips in antiwear material. They have two drawing speeds: the first one in top gear and the second one with reduction rate of 4:1 for larger section wires. They are available in standard version (uses tong BT180T) or short version, supplied with special tong.



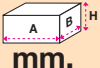

Bancs d'étirage avec une structure solide en fer soudé, dotés de chaîne robuste. Les engrenages tournent sur des boîtes d'essieu à graissage automatique; la chaîne aussi, contrairement aux autres bancs, est soutenue par des bandes de matériau antiusure. Ils sont dotés de deux vitesses d'étirage: la première en prise directe et la seconde avec un rapport de réduction de 4:1 pour les plus gros fils. Ils sont disponibles dans la version standard (utilisent la pince BT180T) ou courte, munie de pince spéciale.

Nuestros bancos trefiladora tienen una estructura totalmente de acero y están provistos de una cadena resistente. La versión manual tiene 2 velocidades de trefilado, la segunda con una relación de reducción 4:1. Diámetro máximo de trefilado mm 10.

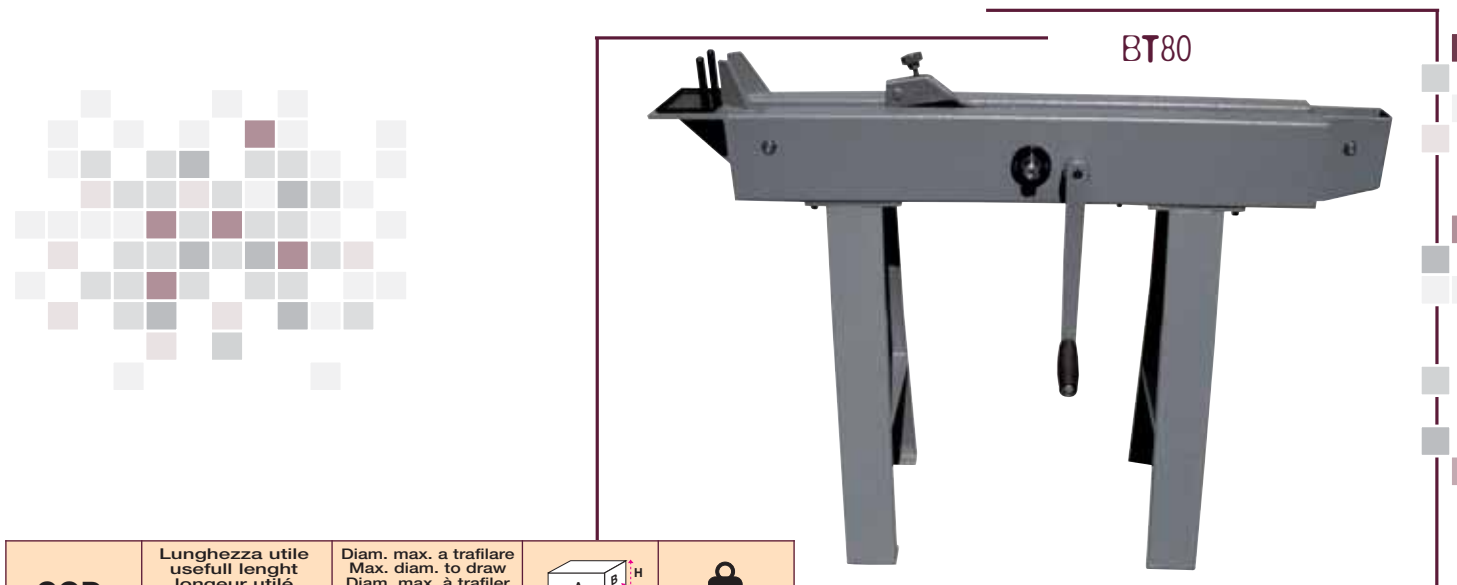
COD.	Lunghezza utile usefull length longeur utilé Largo útil mm.	Diam. max. a trafilare Max. diam. to draw Diam. max. à trafilier Diám. máx de trefilado mm.	 mm.	 Kg
BT180	1300	10	1800x450x800h	55

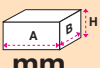

COD.	Lunghezza utile usefull length longeur utilé Largo útil mm.	Diam. max. a trafilare Max. diam. to draw Diam. max. à trafilier Diám. máx de trefilado mm.	 mm.	 Kg
BT80	850	6	1300x450x800h	48